

Broad Lane, Sheffield, S3 7HQ
Telephone: +44 (0) 114 2892000
Facsimile: +44 (0) 114 2892500



Karabiner Safety In The Arboriculture Industry

HSL/2003/18

Project Leader: **J Statham**
Author(s): **J Statham MSc and B Roebuck BSc**
Science Group: **Engineering Control Group**

CONTENTS

1	Introduction	1
2	Project Familiarisation	2
2.1	Background information	2
2.2	Familiarisation visits	2
3	Climbing methods in arboriculture	4
3.1	Factors affecting karabiner behaviour during climbing	4
3.2	Self-locking vs. screw-gate karabiners	5
3.3	Aluminium alloy vs. steel karabiners	6
4	Laboratory Testing	7
5	Examination of karabiners	9
5.1	Examination of new karabiners	9
5.2	Examination of used karabiners	9
5.3	Information supplied by arborist suppliers	10
5.4	Standards applicable to karabiners	10
6	Meetings with karabiner manufacturers	11
7	Maintenance and inspection of karabiners	13
8	Peer review meeting	15
8.1	Techniques for attaching climbing ropes to karabiners	15
8.2	The use of clips to retain the prussik loop	15
8.3	Recommended knots	16
8.4	Harness attachments	16
8.5	The use of pulleys	17
8.6	Back-to-back karabiners	17
9	Conclusions	18
10	References	19
	ANNEX A - Karabiners acquired by HSL for examination and test	32
	ANNEX B - Members of peer review group	33

EXECUTIVE SUMMARY

Following instances of inadvertent opening of three-way karabiners, HSE commissioned HSL to carry out research into the use of karabiners in the arboriculture industry. The objectives of the project were as follows:

1. Collection of background information, including types and range of karabiners available from suppliers, examples of incidents where karabiners had opened, standards for the design and manufacture of karabiners and information on the use of karabiners in other applications.
2. Liaison with users in the arboriculture industry, including consultation with a peer review group whose members were to be put forward by industry trade associations or other stakeholders.
3. Two site visits to observe the use of karabiners, to discuss problems with users and to obtain samples of used karabiners.
4. Examination and photography of different types of karabiners.
5. Internal examination of karabiners to enable materials comparisons and consideration of lubrication methods.
6. Testing of karabiners to include: the effects of rope snagging; swivelling of the karabiner; the effects of dirt and debris; the effects of different loading conditions, including external forces on the gate; an assessment of the risk of roll out; and, an assessment of the factors affecting the risk of roll out, including knurling on the barrel, the mode of opening and the design of the nose of the karabiner.
7. Production of a formal report that could be made available to users and suppliers. The report would identify problem areas and provide recommendations for improvements in both design and use and recommendations for maintenance and care.

As a result of consultation with the peer review group, it was later agreed that the project be extended to include a visit to Newton Rigg College, where techniques for reducing the risk of karabiners becoming detached were discussed, demonstrated and photographed.

Main Findings

- 1 Using current standard climbing methods, existing 3-way karabiner design cannot be relied upon completely to retain the climbing and prussik rope securely when used in the arboricultural industry.
- 2 The climbing and prussik rope can become detached from the karabiner for two reasons.
 1. The gate can be opened due to contact with climber, equipment or tree or;
 2. The gate can fail to initially close. It is possible that some reported incidents were caused by a combination of both.
- 3 Some types of 3-way karabiner do not close reliably even when new.
- 4 Contamination of the 3-way karabiner mechanism can result in failure to close reliably.

- 5 Karabiners should be inspected by users more frequently and thoroughly than would appear common practice at present. The inspection should pay particular attention to the reliability of closure.
- 6 Karabiners should be replaced more frequently than would appear commonplace at present. They do not have an infinite life but many arborists do not know how to identify when a 3-way karabiner needs to be replaced. Maintenance in order to free sticking karabiners is often short term and, depending on contamination, cleaning can be impracticable. Replacement is therefore sometimes more appropriate.
- 7 Techniques have been recommended for attaching climbing and prussik ropes to the karabiner which can improve the security of these ropes in the karabiner. Use of these techniques will reduce the risk of existing designs of karabiner becoming detached.
- 8 The use of back-to-back karabiners to increase the security is impracticable.
- 9 Returning to the use of screw-gate karabiners will not solve the current problems but only reinstate earlier ones. The use of steel rather than alloy may also present as many problems as it would solve.
- 10 Many used 3-way karabiners do not close reliably. This in some cases is attributable to the karabiner design.
- 11 To improve karabiner safety, the security of the closure and locking mechanism must be improved. This will require design changes in order that they perform better in the arboriculture industry.
- 12 Karabiners need to be supplied with a practicable maintenance method appropriate to the industry in which they are being used.

1 INTRODUCTION

Following instances of inadvertent opening of three-way karabiners, HSE commissioned HSL to carry out research into the use of karabiners in the arboriculture industry. The objectives of the project were as follows:

1. Collection of background information, including types and range of karabiners available from suppliers, examples of incidents where karabiners had opened, standards for the design and manufacture of karabiners and information on the use of karabiners in other applications.
2. Liaison with users in the arboriculture industry, including consultation with a peer review group whose members were to be put forward by industry trade associations or other stakeholders.
3. Two site visits to observe the use of karabiners, to discuss problems with users and to obtain samples of used karabiners.
4. Examination and photography of different types of karabiners.
5. Internal examination of karabiners to enable materials comparisons and consideration of lubrication methods.
6. Testing of karabiners to include: the effects of rope snagging; swivelling of the karabiner; the effects of dirt and debris; the effects of different loading conditions, including external forces on the gate; an assessment of the risk of roll out; and, an assessment of the factors affecting the risk of roll out, including knurling on the barrel, the mode of opening and the design of the nose of the karabiner.
7. Production of a formal report that could be made available to users and suppliers. The report would identify problem areas and provide recommendations for improvements in both design and use and recommendations for maintenance and care.

As a result of consultation with the peer review group, it was later agreed that the project be extended to include a visit to Newton Rigg College, where techniques for reducing the risk of karabiners becoming detached were discussed, demonstrated and photographed.

2 PROJECT FAMILIARISATION

2.1 BACKGROUND INFORMATION

A range of background information, including the range of karabiners available from suppliers, examples of incidents where karabiners had opened, standards for the design and manufacture of karabiners as well as information on the use of karabiners in other applications was gathered and assessed. This was followed up by telephone contact with manufacturers and suppliers of karabiners as well as detailed discussions with the HSE project officer and members of the peer review group.

2.2 FAMILIARISATION VISITS

In addition to the background information described above, the project included two familiarisation visits in order to allow arboricultural work to be witnessed first hand. The visits also provided opportunity to discuss with arborists the different techniques they used to climb trees and the advantages and disadvantages encountered with these techniques. The visits also provided an opportunity to examine the climbing equipment used by arborists, to see it used in a working environment and how this could potentially affect its use. These visits included one day at Trees Unlimited near Leeds and one day at an HSE organised training event provided by Treerevolution.

The first visit to Trees Unlimited started with a demonstration of the basic climbing kit used. This included the work positioning harness, static climbing rope and prussik rope or loop. The different techniques, and ways in which these could be used to form a climbing system were demonstrated. The visit also included demonstrations of the basic climbing techniques commonly used in arboriculture. This involves the use of the climbing and prussik rope configured as shown in Figure 1. A body thrusting technique is then used to ascend the climbing rope in conjunction with the prussik knot. The demonstrations also included the use of more advanced equipment and techniques such as the use of pulleys to assist the upward movement of the prussik knot. It should be noted that where a prussik knot is referred to, other friction knots or devices might be used.

It was clear during the climbing demonstrations that dust and debris from tree surfaces was continually present in the vicinity of the karabiner. The climbing action sometimes involved the climbers' feet being pressed against the tree while prussiking, producing debris as the climbing progressed. At certain stages of the climbing, close contact between the climber and the tree was unavoidable, leading to the karabiner being trapped between climber and tree. It was clear from the demonstrations and the discussion with the climber that the amount of debris and subsequent contamination of the climbing equipment could vary considerably. This was dependant on the type of tree being climbed, the weather at the time of the operation, and the time of year, which could also affect the tree condition. These factors would influence how quickly the climbing equipment, in particular the karabiner, would become contaminated.

While the visit did not entail actual tree work, it was clear that a significant amount of equipment was carried on and around the climber while working. Much of the equipment being carried is attached to various points on the harness while climbing. Heavier items such as the chainsaw are lifted into the tree once the tree has been ascended. These items are also then attached to the harness, often by a lanyard.

The second visit was to an arboriculture-training event organised by the HSE at Llanberis. This event also included demonstrations of various climbing techniques, both basic and advanced, as well as the felling of a tree and a simulated aerial rescue. Several arborists were present during the event and it was therefore possible to discuss their climbing techniques and the equipment they used.

The tree work conducted during the event again showed the level and types of contamination, which are typical of this type of work. These included dust and debris from the tree surface while climbing, and sap and wood debris during cutting. Sap was considered by arborists to be the most difficult contaminant to deal with, as certain trees produce sap which can be practically impossible to remove from the climbing equipment. As with other contamination the amount present could vary considerably, and therefore, the frequency with which the equipment, in particular the karabiner, would need to be serviced would also vary. The method of servicing the karabiners, which appears to have been adopted by most arborists present, was to lubricate the karabiner with light oil such as WD40. This, it was suggested, would tend to clean the debris from the karabiner as well as to re-lubricate. Alternatively, washing the karabiner in soapy water followed by drying and re-lubricating was also suggested. All arborists spoken to carried out daily inspections of the climbing equipment including the karabiner. Examination of most of the equipment was straightforward in that it consisted of examination for apparent defects or damage. However, the karabiners also had to be checked for correct operation. The subject of karabiner maintenance and inspection is discussed further in Section 7.

During aerial rescue the rigging can tend to become untidy. Multiple rope attachments may be made to the karabiner and tension cannot be maintained in the original climbing system. Also, the injured climber may not remain in the ideal orientation while being lowered, possibly interacting with the karabiner.

This visit also allowed a number of different types of work positioning harness to be examined. The type of harness could also influence the type of karabiner and attachment used. This is discussed later in Section 8.

It was clear from the demonstrations provided on both visits that the application of the equipment to even basic techniques could vary. It was also clear from discussions with the arborists present on both visits that the choice of climbing technique and the equipment used, such as the work positioning harness and the karabiners, at present is very much a matter of personal choice. All the arborists present had a selection of climbing karabiners, but ultimately their choice was based on experience and personal preference. The climbing methods observed in the above visits are described in further detail in Section 3.

3 CLIMBING METHODS IN ARBORICULTURE

When considering climbing methods in arboriculture work it is important to note that, unlike rope access work arborists use a single climbing line, with no secondary fall protection, except when at the working position. Even then it is acceptable to only have a single attachment point if the climber's assessment of the task is that he or she may have to move quickly to avoid a specific hazard e.g. the cut section may move towards them unexpectedly. The climbing line used is a semi-static climbing line and is therefore not intended to act as fall protection, providing little or no energy absorption. As a result of the above working method, it is important that a karabiner is extremely reliable i.e. that it secures the ends of the climbing rope and prussik rope/loop until opened by the user.

Tree climbing methods fall into two main types: high access, which uses a single high fixing point just above the highest point required to ascend to on the tree; and, the more common method which uses a sequence of shorter stages to ascend the tree.

The method commonly in use in the UK is to ascend the tree in a number of relatively short stages. The number of stages required to climb the tree tends to be determined by the type or condition of tree being climbed, and the length of each stage is often limited by the height to which the climbing rope can be successfully entered into the tree. A very dense tree, for example, may require a large number of very short climbing stages, as little as only a few feet in some cases. Each time the arborist reaches the top of a climbing stage, he/she is required to connect a safety line around the tree, attaching this to the karabiner before the climbing rope is detached from the karabiner to allow the next stage of climbing to be arranged. It can be seen, therefore, that this method typically requires a higher frequency of karabiner operation. Where climbing conditions are difficult, as in dense trees, the arborist may also be required to climb through a mass of tree growth which is likely to impart forces onto the karabiner. The arborist is also likely to have to climb onto the tree limbs in order to gain access. This method clearly results in close and frequent contact between arborist, karabiner and tree. This method is also more likely to result in some slack rope as it can be difficult to retain tension in the climbing rope when climbing onto branches. Guidance in AFAG 401 gives recommendations for keeping slack to a minimum at all times.

The high access method offers advantages to the arborist in that it can save significant time when climbing large trees and also that it can require less effort when climbing. The method, if used correctly, will also tend to prevent slack rope being present in the climbing system and will require significantly less operations of the karabiner. However, this method uses a part of the tree that may be difficult to examine from the ground before climbing commences and therefore presents increased risk of a weak attachment point and subsequent failure. The method is also not appropriate for all types of tree, e.g. those where the crown may be too dense to enable rigging for this method or for direct climbing from base to top. The high access method is not currently common practice within the UK, although it is becoming more widespread.

Another climbing activity that presents increased risk is aerial rescue. This operation is used to recover injured personnel from trees when they are unable to descend the tree themselves. This requires multiple rope attachments to the karabiner and it is difficult to maintain the correct karabiner orientation during some movements. There is also the potential to place full body mass onto the karabiner while the body is being moved.

3.1 FACTORS AFFECTING KARABINER BEHAVIOUR DURING CLIMBING

In order to understand how to address the problems associated with using karabiners in arboricultural work it was important to establish how a karabiner could potentially become detached from the climbing line or prussik loop. The following potential sources have been identified:

- Rubbing action against the karabiner gate or, as it is sometimes referred to, ‘rollout’ could potentially result from contact with either the tree, the climber or ropes. This action on the gate has the potential to partially or fully open the gate, resulting in opportunity for rigging to become detached. The risk of this happening is highest when the climbing rope is slack and the karabiner not in tension. The karabiner design features that affect the risk of rollout are discussed further in Section 4. It should be noted that not all karabiner designs are subject to this mode of failure.
- Loose knots where the prussik loop and climbing rope attach to the karabiner can also have a direct action on the gate mechanism, resulting in the gate opening. Similarly, slack rope in the climbing system may tend to result in the karabiner changing orientation and, combined with loose knots, result in these knots working on the gate mechanism and opening the gate.
- It has been identified that many karabiners do not always fully close when the gate is released. This is discussed in more detail in Section 5. Some karabiners do not fully close every time when new, others deteriorate with use, while nearly all appear to deteriorate relatively quickly when contaminated with debris commonly found in arboriculture work e.g. tree sap and bark debris. The reasons for these failures are discussed in Section 5. It is clear that a karabiner that is not fully closed will not be as secure as intended.

Clearly a combination of the above effects would significantly increase the probability of the climbing or prussik rope being released from the karabiner.

3.2 SELF-LOCKING VS. SCREW-GATE KARABINERS

Currently the recommended practice in arboricultural work is to use a 3-way karabiner of the type commonly referred to as self-locking. This is recommended in AFAG 401, The Guide to Good Climbing Practice and HSE Information Sheet AIS 30. Industry training schemes also advocate this type of karabiner. Previous to this recommendation it was common practice to use a screw-gate karabiner. However, this type of karabiner had not been without problems when used in the arboricultural environment and this is why industry experts begun using and advocating self-locking types of karabiner. A number of incidents, including fatalities, had occurred with screw gate karabiners where arborists had become detached from either the climbing or prussik rope, resulting in falls. Traditionally, screw-gate karabiners are not tightened fully with the climbers load applied as this may result in them being impossible to undo after having the load removed. However current designs of screw gate karabiner are available which overcome this problem. Nevertheless, the screw-gate karabiner needs to be manually locked prior to use and failure by the arborist to do this would result in greatly increased risk of the karabiner becoming detached. It had therefore been assumed that the ‘self locking’ karabiner was safer as it was not subject to human error, i.e. it could not be left unlocked during operation. The common climbing method currently used in the UK also requires a high frequency of karabiner operation, and the screw-gate is relatively slow to operate. This may lead to short cuts, with screw-gate karabiners being left unlocked.

It has been difficult to get a full picture comparing the risks from screw gate karabiners to three way action karabiners. Users are much more likely to report a failure with a 3-way karabiner as it is perceived to be a design fault. However, screw gate near miss incidents are seemingly never reported, as these are perceived to be a result of the climbers omission or acts.

3.3 ALUMINIUM ALLOY VS. STEEL KARABINERS

3-way karabiners are typically manufactured in both aluminium alloy and steel. Currently arborists use alloy karabiners for two reasons. Alloy karabiners are much lighter than steel and therefore make for easier work. The alloy climbing karabiner is also easy to distinguish from the steel ones routinely used in rigging/dismantling work. This distinction is important as the steel karabiners used for rigging are often subject to heavy use and, as a result, may be less reliable.

The use of steel karabiners may have overcome some of the problems identified in Section 5. However, the importance of separating climbing karabiners from those used for rigging is essential. This was the overwhelming view expressed by the peer review group. It was agreed that it should be possible to address the deficiencies identified in Section 5 by other methods. These were discussed with relevant manufactures as described in Section 6.

4 LABORATORY TESTING

The purpose of these tests was to establish how the effects described in section 3.1 could open the karabiners during use. Two tests were devised, which it was intended would simulate the action of the forces to which the karabiners were typically subjected. It is important to note that neither of the test arrangements was intended to replicate the typical arrangement of a karabiner in use, but to simulate the possible forces acting on it. The test arrangements are shown in Figures 2 and 3. A list of the karabiners tested is shown in Annex A.

The first of these arrangements, shown in Figure 2, was intended to simply produce a sliding force across the karabiner gate. The karabiners were mounted horizontally and a rope with a 2kg weight attached was passed over the gate. The rope was then drawn across the gate in a steady manner. The angle at which this force was applied could be varied between tests. A simple protractor was set up behind each karabiner so that the angle during a test would remain constant. The test was also carried out with several different materials, woven nylon, cotton and rope. Two different rope types were used, Mamba Blue, manufactured by Beal Ropes, and Safety Blue High VEE, manufactured by New England Ropes. These both produced similar results, with rope having a greater effect than the other materials. Sliding a rope across the barrel could open many of the karabiners.

The second arrangement was intended to demonstrate how the dynamic effects of prussiking might impart forces onto the karabiner in a different way to the simple sliding test above. The karabiner was arranged vertically on the test rig and the ropes then operated to move the karabiner in an up and down motion over an obstruction. As in the first test setup, a number of materials were used in the rig including woven nylon sheet, various types of wood and rope. Rope again was shown to give the greatest effect on the karabiner gate. This test was of limited success in that it did not provide much information that was not gained from the previous arrangement. The test did show, however, that the gate could again be operated this time by the action of sliding rope across the barrel. The gate was not fully opened but could be moved away from fully closed. To move a karabiner gate further than the first stage of opening required the karabiner to be moved at an oblique angle and with greater force applied than was practicable with the second test set-up.

The tests described above have not produced a definitive set of results intended to qualify karabiners, but have been able to show what effect the different design features of the karabiners have on the operation of the karabiner gate. The tests have shown how factors such as those listed below can effect how items such as rope interact with the karabiner gate:

- Surface finish of the barrel e.g. knurling
- Spring force of both the torsion spring and compression spring
- Barrel shape and profile
- Profile of the locking mechanism

The tests showed that the surface finish was of importance, as the rope could not grip on areas of the karabiner that were not knurled to some extent. This was clear from the effect when the rope passed over areas of the barrel that were not knurled. The type of knurling, displaced or machine cut, also affected the amount of grip generated. The surface finish appeared to have the most effect on how readily the barrel could be operated. The possibility of removing knurling was discussed at the peer review meeting where it was agreed that the karabiners might be operated satisfactorily without knurling.

Spring force was clearly a factor in how easily the gate could be rotated or moved axially. However, in the first test arrangement using a mass of only 2 kg many karabiner gates were found to operate. Those with higher spring rates only required an increase in the mass used and

this would overcome the increased spring force. While increasing spring force may increase the karabiner's resistance to opening in certain circumstances, this may be insignificant when compared with some of the forces generated in practice during climbing, e.g. the mass of an arborist on top of the karabiner when climbing over a branch.

The barrel profile and shape effect how readily the rope could snag on the barrel, particularly at the base of the barrel where cut-outs form the locking mechanism. Some barrels were also tapered towards the end, which tended to prevent the rope snagging. The overall shape of the barrel may also affect the likelihood of snagging and, coupled with surface finish, effect how the gate is operated. Most barrels at present are cylindrical and, when tested, rolled readily. Other shapes may tend to resist rolling and therefore offer resistance to opening. It was not felt that enough different shapes were available to determine which would be of benefit or if drawbacks existed.

The locking mechanisms on the traditional 3-way karabiner all tend to be of a similar design and therefore can be opened in a similar manner by the first test method. The geometry of the mechanism varies slightly but this tends to result in only a different angle of pull required in the test. One design of karabiner required the barrel to be pushed in the opposite direction to all others. This had no effect once the direction of the test was reversed.

All except one design of 3-way karabiner, the Petzl ball lock, are similar in design and therefore function. The Petzl karabiner could not be opened at all by the above tests and must be regarded as more secure when locked than other types tested.

The above tests were demonstrated to the peer review group during the project as well as to manufacturers who visited HSL. No one expressed reservations about the test arrangements or their outcome.

The tests have demonstrated how the majority of the 3-way karabiners currently being used are readily opened by the action of rope sliding over the surface of the karabiner gate with only a small force applied. This demonstrates that the typical 3-way design of karabiner cannot be considered to be completely secure when used in the arboriculture environment.

5 EXAMINATION OF KARABINERS

5.1 EXAMINATION OF NEW KARABINERS

All karabiners examined were manufactured primarily from aluminium alloy (except gate components) as used currently in arboriculture. A list of the karabiners acquired and examined is included at Annex A. As many types of karabiner as possible were acquired in order to identify if any had inherent design or manufacturing problems or indeed if any had design or manufacturing superiority. In order to simplify comparison it was decided to acquire only one design of karabiner from each manufacturer as, in most cases, the same gate design is employed across a range of models.

Two distinct types of alloy karabiner are currently available to arborists; the Petzl ball lock karabiner and the generic 3-way design with twist, push and turn to operate the gate mechanism. The Petzl karabiner appears to be the only karabiner with a barrel manufactured of plastic, where others tend to be either alloy or brass.

While many of the generic 3-way karabiners appear to be very similar, some subtle differences exist when examined closely: these include the spring rates, the profile of the locking mechanism; clearances between components; and the provision of bushes between components. The spring rates can vary on the gate closing spring, the barrel rotation spring and the longitudinal spring. The profile of the locking mechanism on the barrel determines the sequence of movements required to open the karabiner as well as the closure of the gate. The profile of this mechanism is one feature which directly determines the difficulty required to open this type of karabiner. The clearances, which manufacturers provide between individual components of the gate, also vary between manufacturers. These clearances could determine the way in which contamination enters and affects the operation of the gate. Some karabiners are designed with plastic bushes between the barrel and internal components, whereas others rely on metal-to-metal contact. This difference is discussed further in Section 7.

The examinations showed that some karabiners do not close reliably when new. That is, if the gate were not released from the fully open position, the karabiner would not always fully close. It was not possible to determine the number of times a karabiner failed to close, as many factors could influence the closing action. In order to determine reliability it would be necessary to derive a more systematic method of testing. This was beyond the remit of this project. However, if a karabiner fails to close when new it is unlikely that it will improve with use, and it is conceivable that the performance will deteriorate.

The specific problems identified in the examination of both new and used karabiners were discussed with the respective manufacturers along with the broader karabiner design issues. These discussions are described in further detail in Section 6.

5.2 EXAMINATION OF USED KARABINERS

As with the new karabiners, all the used karabiners examined were manufactured of aluminium alloy. The used karabiners were acquired from several sources, some having been involved in incidents others having been removed from service due to concerns about their reliability and others which had just been well used.

Where a particular failure had been identified the karabiner was examined closely in order to determine the cause of the failure. One failure mode, which gave particular concern, was where

the stainless steel pin, which formed the locking mechanism, had worn through the anodised surface finish of the aluminium alloy barrel. This illustrated is shown in Figure 4. This wear resulted in increased friction between the barrel and pin, which prevented the barrel rotating to the fully closed position. Lubrication in this area may have overcome this problem but in such a small area would have been only a short term solution and, at best, unreliable given the likelihood of contamination. Other similar designs employed a brass bush around the locking pin that appeared to prevent this wear occurring in the body of the barrel. The brass would tend to be self-lubricating when acting on the anodised finish of the barrel and, in one example, appeared to have deposited a thin film of brass onto the aluminium body.

A sample of karabiners with plastic barrels were supplied for examination and reported to have been failing to close fully. These were relatively new karabiners. These karabiners were examined and found to contain little or no contamination or debris. Further examination could not determine the cause of the failure to close. This problem was raised with the manufacturer's UK agents.

A number of used karabiners were examined where contamination was present. Clearly contamination can play a significant role in the karabiner failing to close effectively.

5.3 INFORMATION SUPPLIED BY ARBORIST SUPPLIERS.

While acquiring many of the new karabiners, contact was made with arborist suppliers who had experience of the karabiners that are available in the UK. While opinion varied as to which type of karabiner was the best, it was generally the view that none were ideal. Generally most suppliers tended to stock a selection of different types of karabiners from different manufacturers.

Some arborist suppliers had direct experience of karabiners that did not close fully when new. Where this had been identified these were regarded as unacceptable and had been withdrawn from sale.

Some arborist suppliers were also concerned by the apparent unreliability of some karabiners, which had only been in service for a relatively short period of time.

5.4 STANDARDS APPLICABLE TO KARABINERS.

At present there are a number of standards that apply to the types of karabiner currently being used by arborists, though none apply specifically to this application. None of the standards address the performance of the karabiner from a security or reliability point, focusing mainly on the strength of the karabiner. It may be helpful if security and reliability criteria can be adopted in some form into the standards in the future. This may then help manufacturers to establish the performance of their product and users to identify when the karabiner is no longer serviceable.

6 MEETINGS WITH KARABINER MANUFACTURERS

A number of meetings were arranged with karabiner manufacturers from the UK and representatives of manufacturers from outside the UK. These meetings were arranged to discuss the findings of the tests described in Section 4 and the examination of karabiners detailed in Section 5.

The meetings were used to discuss both HSL's specific concerns regarding the design of individual 3-way karabiners as well as the broader design issues, with a view to improving karabiner designs for use in arboriculture. The following subjects were discussed as areas where improvement might be made in order to improve performance, in particular to improve the reliability of closure and security of the karabiner when closed.

Materials

The examinations carried out in Section 5 had shown that the material used for the pin of the locking mechanism on some traditional 3-way karabiners had created an area of wear on the barrel. This effected the reliability of closure. Manufacturers expressed the opinion that this could be overcome by lubrication. However, in the authors' opinion, this would only present a temporary solution, which would not be appropriate for the duty to which these karabiners are subjected. It was agreed that the manufacturers affected by this problem would look at possible solutions. These may include the use of surface finishes to improve the wear properties of the barrel or bushes on the locking pin which have better self lubricating properties when combined with the anodised alloy barrel.

Lubrication

Most lubricants used by manufacturers are silicone based. These are sometimes applied as a paste or grease to the internal components of the karabiner gate. The lubrication is intended to be long lasting. It was agreed that this might not be the best lubricant when the types of contamination found in arboriculture are present. Silicone lubricant is also difficult to remove once contaminated. It was put to manufacturers that the recommended maintenance information provided with karabiners was inappropriate, and insufficient, for the arboriculture industry. Other types of lubricant that were discussed included dry lubricants with PTFE content.

Maintenance method

Manufacturers were aware that arborists need to maintain the karabiners they used by cleaning and lubricating, but were possibly unaware of the frequency at which this may need to be carried out. Manufacturers do not currently provide suitable methods for cleaning their products when contaminated with material such as tree sap. It was agreed that to do this would be difficult, particularly in the standard pictorial format of instruction, which are issued worldwide. It may be possible to issue separate more specific instructions with this type of karabiner, as 3-way karabiners are generally only used by arborists and supplied through arboricultural suppliers.

Clearances

It was agreed that clearances may need to be increased in order to allow adequate cleaning and prevent interference when lubrication is contaminated. Too large a clearance may encourage the ingress of dirt and debris, but a compromise may be able to be found.

Examination

Currently manufacturers do not recommend a method of examining karabiners. It was agreed that it could be difficult to establish when a karabiner is beyond its useable life. Mechanical defects or damage should be easily spotted but unreliable operation was more difficult to determine.

Surface finish

Most manufacturers of the traditional 3-way karabiner use some form of knurling on the karabiner barrel. It was clear from the demonstrations given to manufacturers of the test described in Section 4, that the surface finish of the karabiner barrel is a significant cause of rollout. It was agreed that this would be given consideration and, if appropriate, could probably be modified relatively easily.

Other areas discussed included the shape and profile of the barrel and how this may be designed to reduce rollout and snagging with ropes. The design of the locking mechanism was also discussed. Manufacturers were concerned that they need to balance the ease of use of the karabiner with security, but recognised that rollout was an unacceptable risk in this industry at present. The possibility of manufacturers providing a means by which a karabiner can be checked either audibly or visibly to ensure closure each time it is used was also discussed.

The meetings provided a useful exchange of ideas and resulted in commitment from those concerned to examine ways of improving the current design of 3-way karabiner for use in arboriculture.

7 MAINTENANCE AND INSPECTION OF KARABINERS

It has been very difficult to establish the frequency with which arborists carry out maintenance of karabiners. This is somewhat understandable as the working conditions can vary substantially. Difficult conditions may determine that maintenance is done every day whereas a relatively clean environment would result in longer maintenance intervals. However, in many cases it would appear that at present maintenance is often carried out only when an inspection identifies that a problem exists. This may be too late. Maintenance needs to be carried out routinely and before problems arise. A malfunctioning karabiner that is identified during inspection is likely to have been in use while unserviceable.

Routine inspections generally consist of a visual inspection of the karabiner for defects or damage and a check of the operation of the gate mechanism. However, with most current karabiner designs it is very difficult to determine the condition of the internal components of the karabiner gate or the level of contamination by external examination alone. Therefore, an operational check may not be representative of the reliability of the mechanism, which may have deteriorated from its original condition. Most karabiner designs contain one or more small springs inside the gate mechanism which are important to the correct operation of the karabiner. A more thorough test of repeated opening and closure, from an almost closed position, might be more indicative of reliability of closure. It is important that the karabiner is tested from an almost closed position so that the energy stored in the gate is not used to operate the gate mechanism, as this may not be representative of the most demanding expectation of the karabiner in use.

Current methods of maintenance include washing or soaking the karabiner in soapy water to remove contamination. This may well remove some contamination e.g. wood dust or fragments, but is unlikely to remove tree sap or debris, which has contaminated the original karabiner lubrication. Contaminated oil-based lubricants such as WD40, which are often used to re-lubricate karabiners, are also unlikely to be removed by this method. Other methods include rinsing or flushing the karabiner with WD40. This acts as a solvent when first applied and is possibly more successful at removing some contamination and will then also provide lubrication. However, it may be difficult to determine if all contamination is removed. Tree sap may still be difficult to remove with this treatment. Karabiner manufacturers or suppliers need to be consulted to ascertain if this method is suitable for their product. Depending on the type of contamination and the original or subsequent lubricant these methods may not be effective. Other methods suggested include using air pressure to blow out debris from the internals of the gate. This method is unlikely to work except in a limited number of cases where debris is dry and no adhesive lubrication is present. It also introduces a new hazard to control for those doing the maintenance.

Appropriate cleaning methods may necessitate the use of solvents in order to remove contamination from within the karabiner gate. The solvent will need to be able to remove contaminated lubricant as well as other contaminants such as tree sap. Tree sap can be particularly difficult to remove even when still tacky. If tree sap is allowed to dry this can be almost impossible to remove, even with aggressive solvents, and would be unaffected by soap and water. The cleaning action will also need to ensure that contamination within the gate is not just disturbed but flushed out. Therefore it will be necessary to conduct the cleaning in for example a container, repeating the cleaning cycle, in order that the cleaning agent can be examined to determine when all traces of contamination are removed. Any solvents used on a karabiner will need to be checked with the manufacturer or supplier in order to establish if it is compatible with the materials used in the karabiner. These may include, for example, plastic bushes that may deteriorate or swell when in contact with solvents, leading to further problems. Cleaning will then need to be followed by suitable lubrication and testing for reliability of operation.

Discussions with arborists and karabiner manufacturers would suggest that these and other methods might be inappropriate in this environment. Other lubricants, which have been suggested for use on karabiners in this environment, include dry graphite powder. While this may provide sufficient lubrication, it has low adhesion and is therefore unlikely to last long in the conditions encountered. Again this type of lubricant needs to be applied to clean components.

Dry PTFE lubricants provide good lubricating properties without excessive adhesion to contaminants. Contaminants that do adhere to the lubricant can tend to be shed from the surface of the lubricant rather than causing build up of matter. This ability to shed contaminated lubricant can also reduce the period between lubrication, as lubricant is lost with the debris. Dry PTFE lubricant can also be removed relatively easily with less aggressive solvents. Water-soluble degreaser can be used allowing components to be rinsed in water. It should be noted that these lubricants do not have the adhesion of traditional oil or silicone based lubricant and therefore would need to be replenished more frequently. For optimum performance dry PTFE lubricant needs to be applied to clean components and may need to be compatible with the manufacturer's own lubricant if this is not removed fully.

It should be noted that any proposed maintenance or inspection methods, as well as being approved by the manufacturer of a particular karabiner, would also need to be tested in the field in order to establish if they are beneficial to karabiner operation and appropriate for the arduous conditions. It is not expected that improvements to current maintenance practice will provide a long-term solution to existing problems with some karabiner designs. These improvements in conjunction with other changes may improve reliability but ultimately more significant changes will be required.

Manufacturers may need to reconsider the type of lubrication that is initially applied during manufacture. These tend to be chosen to provide high adhesion and long service. However, these properties can also tend to make the lubricant difficult to remove once contaminated. Manufacturers may also need to consider their guidance on inspection and maintenance for this particular industry, as well as providing guidance on what may be regarded as a reasonable service life in this industry.

Some karabiners examined in the field by the author and a karabiner manufacturer were found to be in what was considered a poor condition in respect of contamination around the gate components. These were by no means untypical. Others were also examined which appeared to have been used for a long time. That is not to say that they did not still function satisfactorily, but, discussions with arborists suggest karabiners are only replaced when defects result in a karabiner becoming faulty. It may be that many karabiners are being used beyond what manufacturers expect to be a reasonable service life. However, there appears to be no clear indication when a karabiner should be replaced. Given some of the difficulties in cleaning and maintaining the karabiners, described above, it would seem appropriate that karabiners should be replaced more frequently. Also, unserviceable karabiners would be better disposed of rather than being relegated and retained just in case they may be needed.

8 PEER REVIEW MEETING

Part of the project specification was to hold peer review meetings in order to enable representatives from the arboriculture industry to have an input to the direction of the research. A list of the attendees and whom they represent is shown at Annex B.

The meeting was held mid-way through the project to allow any feedback to be incorporated into the remainder of the project. The meeting consisted of a brief outline of the progress so far and preliminary findings, followed by a demonstration of the test arrangements described in Section 4 and how many 3-way karabiners could be opened relatively easily. The group then used the remainder of the meeting to exchange ideas about how the current situation could be improved. This included a number of ideas put forward for improving the way in which karabiners are used, including the use of different knots and devices to improve the attachment of the climbing and prussik rope/loop. These ideas are described in further detail below. An offer was made at the meeting to use climbing facilities at Newton Rigg College to explore the practicalities of these ideas further. It was agreed that ideas would be gathered and a visit made.

8.1 TECHNIQUES FOR ATTACHING CLIMBING ROPES TO KARABINERS

In discussions with both karabiner manufacturers and with representatives from the arboriculture industry it became clear that the problem of karabiners becoming detached from climbing ropes could not be solved quickly. It was, however, agreed with representatives from the industry that techniques were available which could significantly reduce the risk of this occurring. Although the risk of opening of the karabiner could only be significantly reduced by changes in design, the risk of the rope becoming detached from the karabiner could be reduced by:

- i) keeping the prussik loop captive on the karabiner using clips;
- ii) using tight knots onto the karabiner to reduce the risk of them passing over the karabiner barrel or moving round the curves of the karabiner. This applies to the climbing rope, the prussik loop and the attachment to the harness. Knots also keep the rope/karabiner joint stiff, helping to prevent the karabiner from turning and the load being applied across rather than in line with the karabiner;
- iii) reducing the time during which slack rope was present.

8.2 THE USE OF CLIPS TO RETAIN THE PRUSSIK LOOP

The standard attachment of a prussik loop is shown in Figure 1. The prussik rope is nearest the karabiner spine and the climbing rope nearer the gate. Figure 5 shows poor attachment of the prussik loop. It can be seen that the prussik loop is nearer the gate and also slack, allowing movement within the karabiner. In this position, it could potentially become hung up on the karabiner barrel or even become detached if the karabiner gate were to come open. If the karabiner gate were not secure then it would be possible for the rope to twist open the gate and become detached as the rope tightens.

Figure 6 shows a similar arrangement with the prussik loop held in position by a steel clip, sometimes known as a fast clip. The loop cannot move around within the karabiner and is correctly positioned on the spine side of the climbing rope rather than the gate side. Clips made from high tensile steel are preferred because they do not deform as easily as mild steel clips and therefore do not slide around the karabiner. They also have no welds, which might potentially cause abrasion of the prussik loop over time. Note that , if the clip breaks, the situation is no worse than not having a clip at all.

Cheaper options are elastic bands, Figure 7, and plastic clips, Figure 8. Elastic bands are expected to last only for a day, whilst plastic clips should last for a week.

8.3 RECOMMENDED KNOTS

A typical knot for attaching the support rope to the karabiner is the double bowline shown in Figure 9. When the rope is slack, however, this knot is also able to move around the karabiner, potentially interfering with the karabiner barrel and able to slip over the barrel and off the karabiner if the gate is not locked. Better arrangements are shown in Figures 7 and 8 where a tight termination has been used to attach the karabiner to the support rope.

Figure 9 also shows the use of a double fisherman (or barrel) knots to attach the prussik rope to the karabiner. Although bulkier than a clip, this also prevents the knots from being able to move easily around the karabiner. Alternative knots to attach the prussik loop to the karabiner are the double fishermans sliding knot, Figure 10 and the larks foot, Figure 11.

In general, rope terminations with small eyes, which prevent the eye from passing over the karabiner barrel, are better. Where knots are used to attach the prussik loop, self-tightening knots are preferred.

8.4 HARNESS ATTACHMENTS

Selection of a harness will often be a matter of personal choice and a common feature is the butterfly loop as seen in Figure 10. This allows the karabiner to move across the front of the user and provides more flexibility of movement. Its disadvantage is that, when the rope is slack, it can move within the karabiner and is free to foul on the karabiner barrel when the rope re-tightens.

Alternatives we have seen include the use of a swivel, attached to the harness using a maillon, see Figure 8 and, for operating at height rather than climbing, a split support line as shown in Figure 12. The swivel is said to take the twist out of the support rope and also moves the karabiner further away from the body.

One harness we saw included small tight loops at various positions across the front of the wearer, allowing the attachment point to be moved but perhaps more importantly, holding the karabiner captive so that it could not rotate relative to the harness.

Harnesses should always be used in accordance with the manufacturers instructions. Some makes of harness with the front webbing strap are designed for pole climbing and the instructions indicate that the side attachment points should be used.

8.5 THE USE OF PULLEYS

Figures 13 and 14 show two arrangements using pulleys attached to the support rope and assisting the prussik loop in being pushed up the support rope. The pulley is easily controlled by one hand pulling up the tail of the lifting rope and the need for slack rope is significantly reduced. A second advantage is that the pulley leads the support rope into the prussik knot, helping to preserve the shape of this knot. If the time during which slack rope is present can be reduced then the risk of the karabiner becoming detached is also reduced.

Pulleys provide other advantages, including one-handed operation and allowing the use of both hands when body thrusting. It is considered essential, however, that operators are properly trained in their use.

8.6 BACK-TO-BACK KARABINERS

The use of back-to-back karabiners has been recommended as a possible way of reducing the risk of ropes becoming detached from karabiners. This technique is not, however, recommended in the arboriculture industry because of the need for 3 connections to the karabiner, making any joint with back-to-back karabiners complex and bulky, and the need in arboriculture to disconnect and reconnect the karabiner during multi-stage climbing. This technique is also impossible to implement in conjunction with small eye terminations and other recommendations included earlier in this report.

9 CONCLUSIONS

- 1 Using current standard climbing methods, existing 3-way karabiner design cannot be relied upon completely to retain the climbing and prussik rope securely when used in arboricultural industry.
- 2 The climbing and prussik rope can become detached from the karabiner for two reasons.
 1. The gate can be opened due to contact with climber, equipment or tree; or
 2. The gate can fail to initially close. It is possible that some reported incidents were caused by a combination of both.
- 3 Some types of 3-way karabiner do not close reliably even when new.
- 4 Contamination of the 3-way karabiner mechanism can result in failure to close reliably.
- 5 Karabiners should be inspected by users more frequently and thoroughly than would appear common practice at present. The inspection should pay particular attention to the reliability of closure.
- 6 Karabiners should be replaced more frequently than would appear commonplace at present. They do not have an infinite life but many arborists do not know how to identify when a 3-way karabiner needs to be replaced. Maintenance in order to free sticking karabiners is often short term and, depending on contamination, cleaning can be impracticable. Replacement is therefore sometimes more appropriate.
- 7 Techniques have been recommended for attaching climbing and prussik rope to the karabiner, which can improve the security of these ropes in the karabiner. Use of these techniques will reduce the risk of existing designs of karabiner becoming detached.
- 8 The use of back-to-back karabiners to increase the security is impracticable.
- 9 Returning to the use of screw-gate karabiners will not solve the current problems but only reinstate earlier ones. The use of steel rather than alloy may also present as many problems as it would solve.
- 10 Many used 3-way karabiners do not close reliably. This in some cases is attributable to the karabiner design.
- 11 To improve karabiner safety, the security of the closure and locking mechanism must be improved. This will require design changes in order that they perform better in the arboriculture industry.
- 12 Karabiners need to be supplied with a practicable maintenance method appropriate to the industry in which they are being used.

10 REFERENCES

AFAG 401, Tree climbing operations, HSE publications, 04/03

A Guide to Good Climbing Practice, FASTCO/Arboricultural Association, 1999 - available from HSE publications.

HSE Information Sheet AIS 30. – LOLER : How the regulations apply to arboriculture 10/00.



P5140001.jpg

Figure 1 – Basic configuration of climbing and prussik ropes.

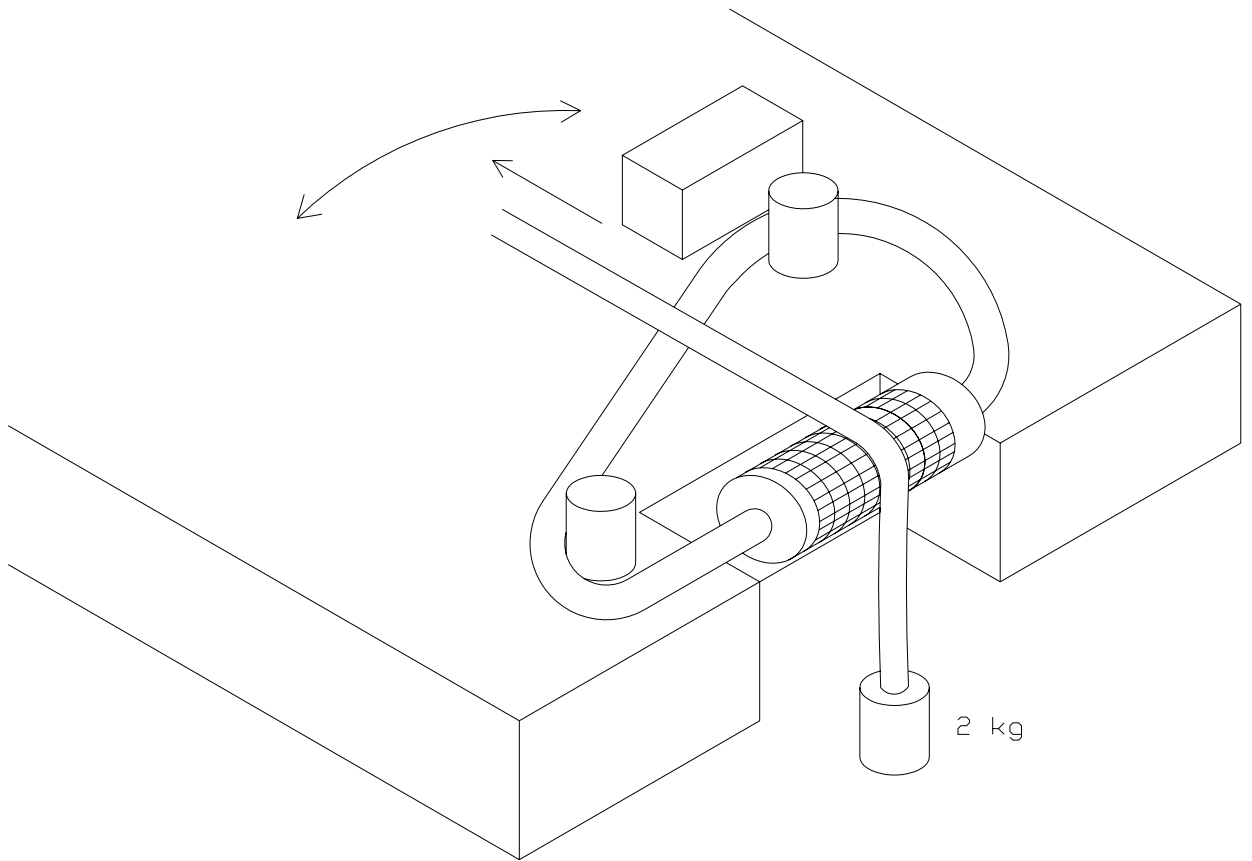

Jonathan Karibiner2.dwg

Figure 2 – Initial test arrangement.

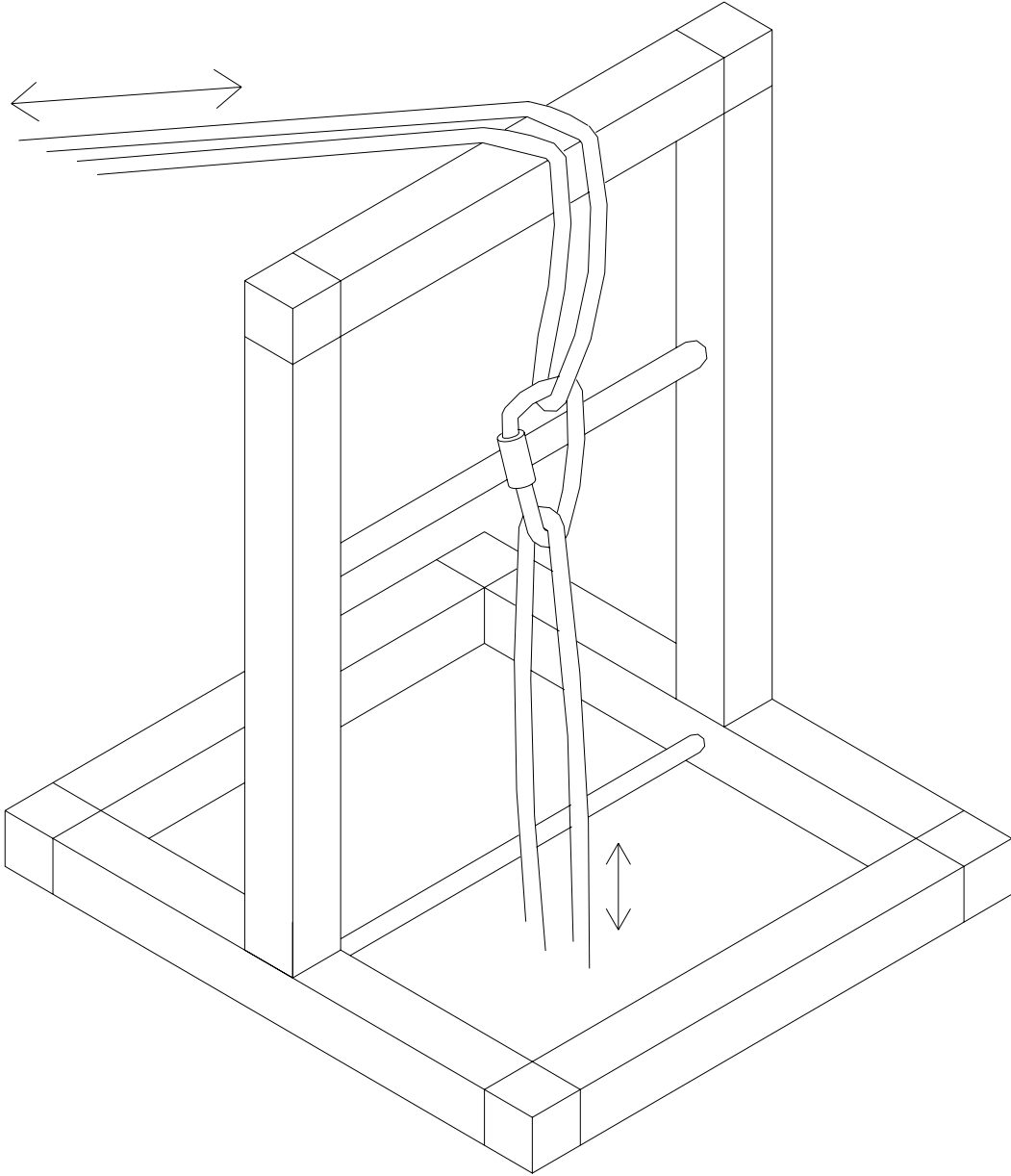

Jonathan Karibiner1.dwg

Figure 3 – Second test arrangement.

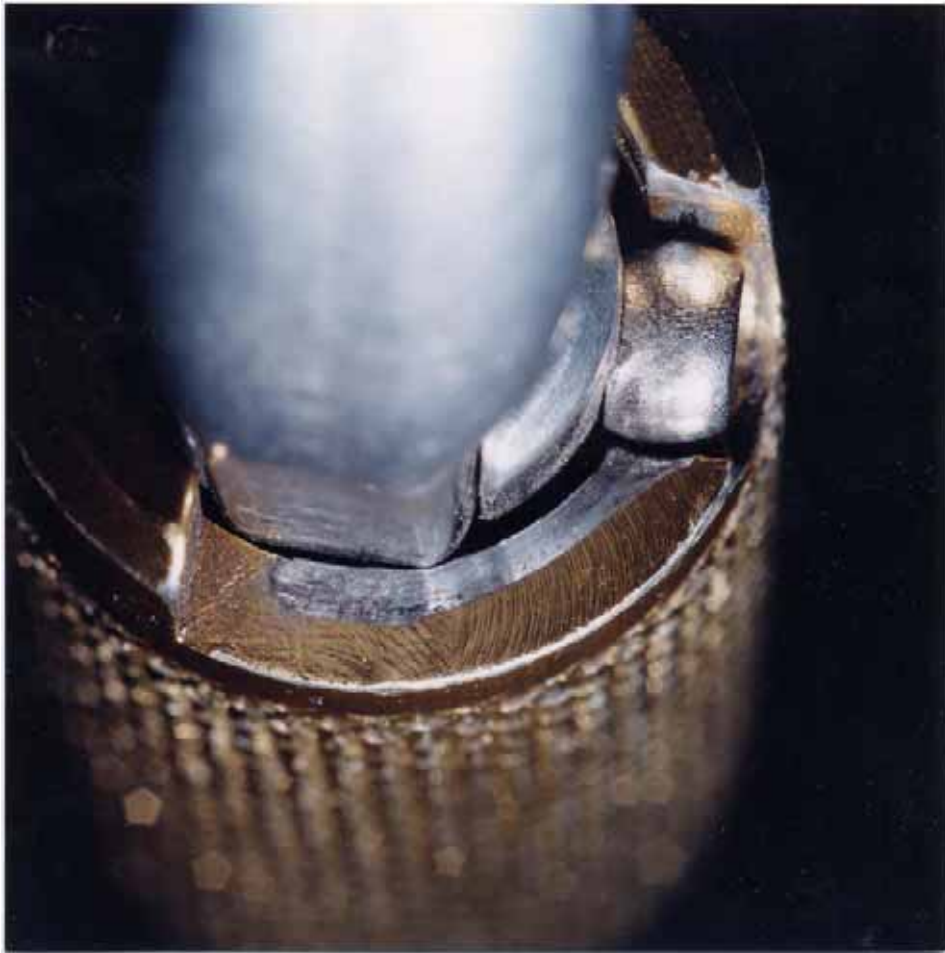

0208-022/15

Figure 4 – Wear on aluminium alloy barrel.

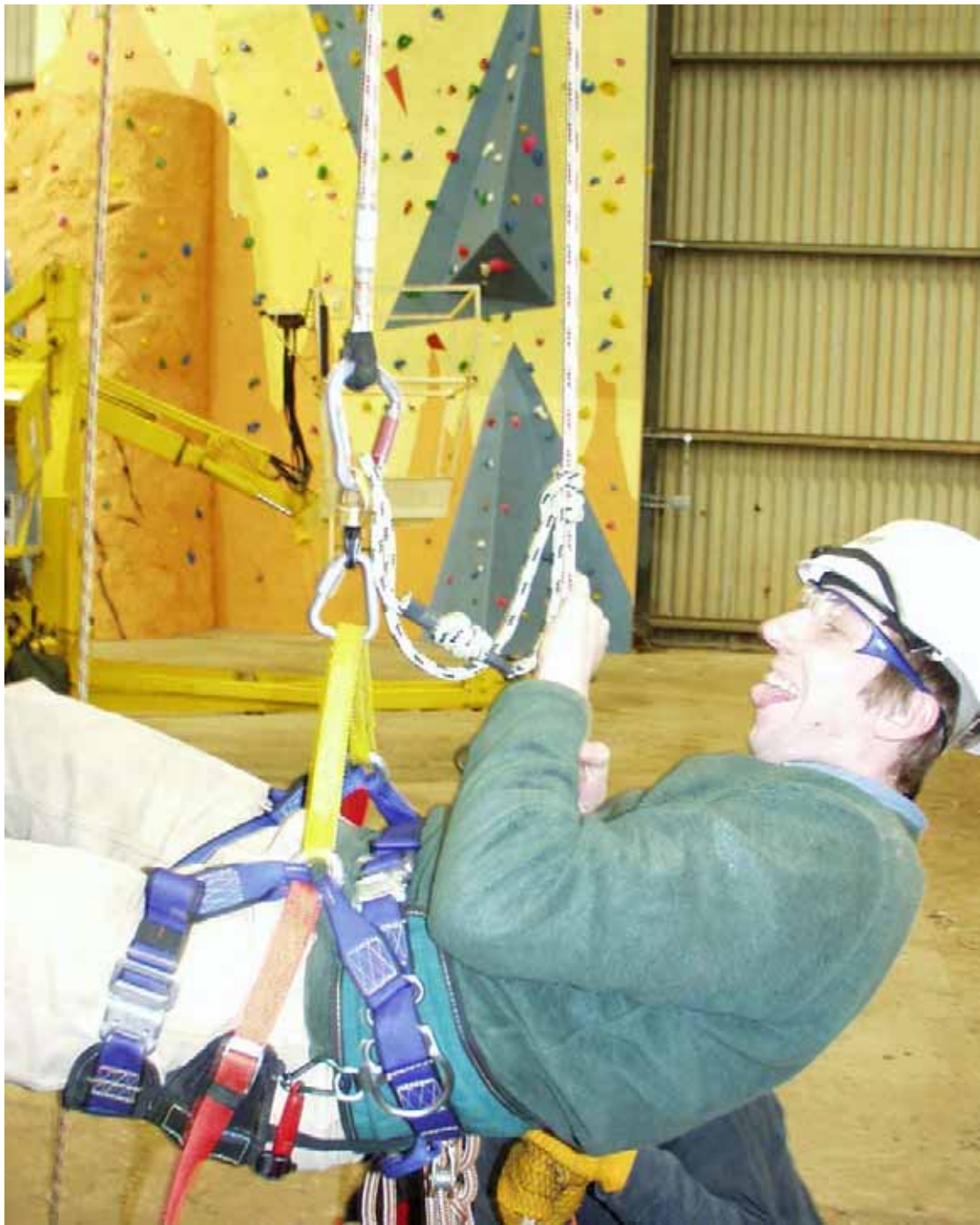

P3120010.jpg

Figure 5 – Poor attachment of prussik loop.

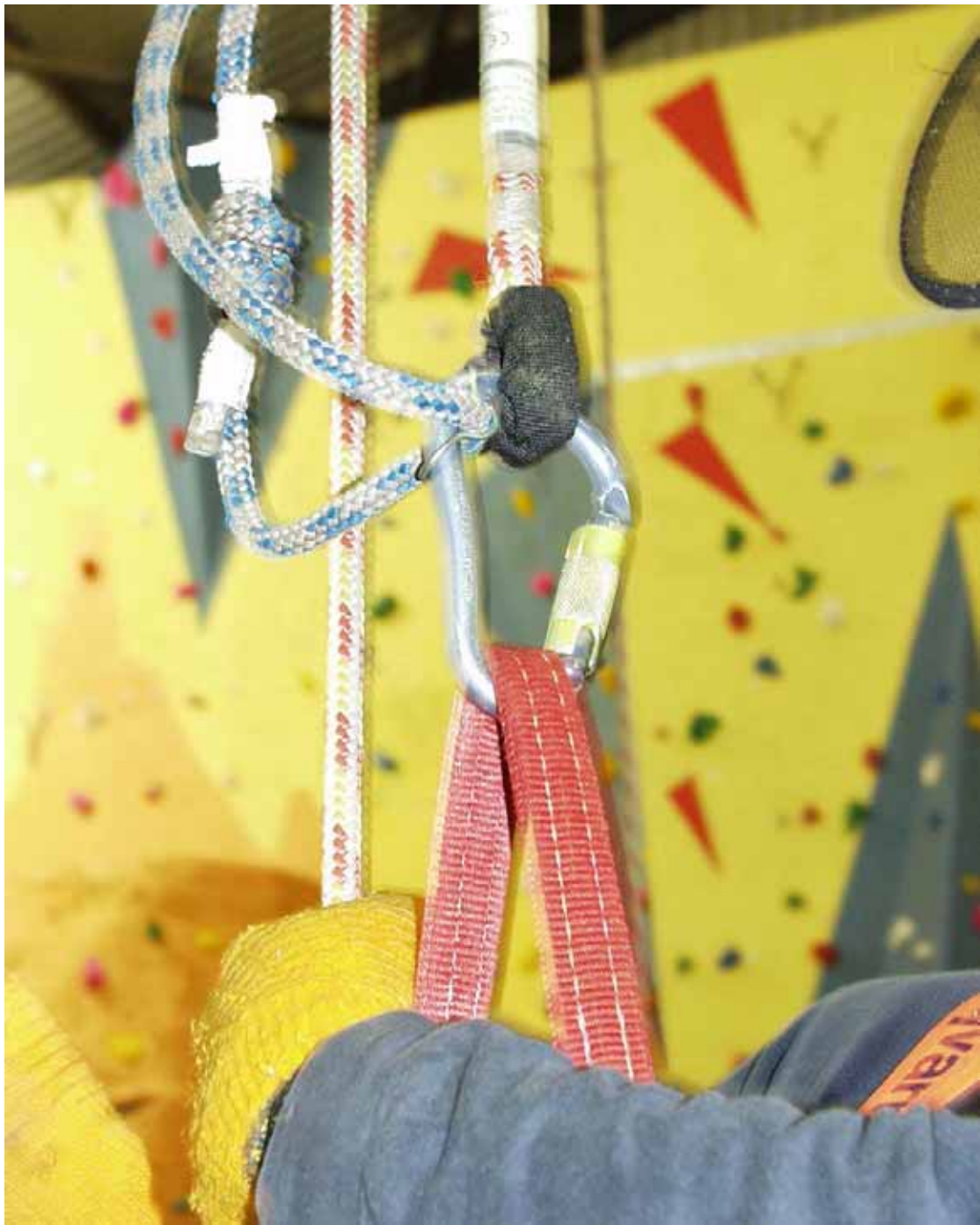

P3120008.jpg

Figure 6 – Prussik loop held by steel clip.



P3120012.jpg

Figure 7 – Prussik loop held by elastic band.



P3120017.jpg

Figure 8 – Prussik loop held by plastic clip.



P3120015.jpg

Figure 9 – Double fisherman's or barrel knot.



P3120011.jpg

Figure 10 – Double fisherman's sliding knot.

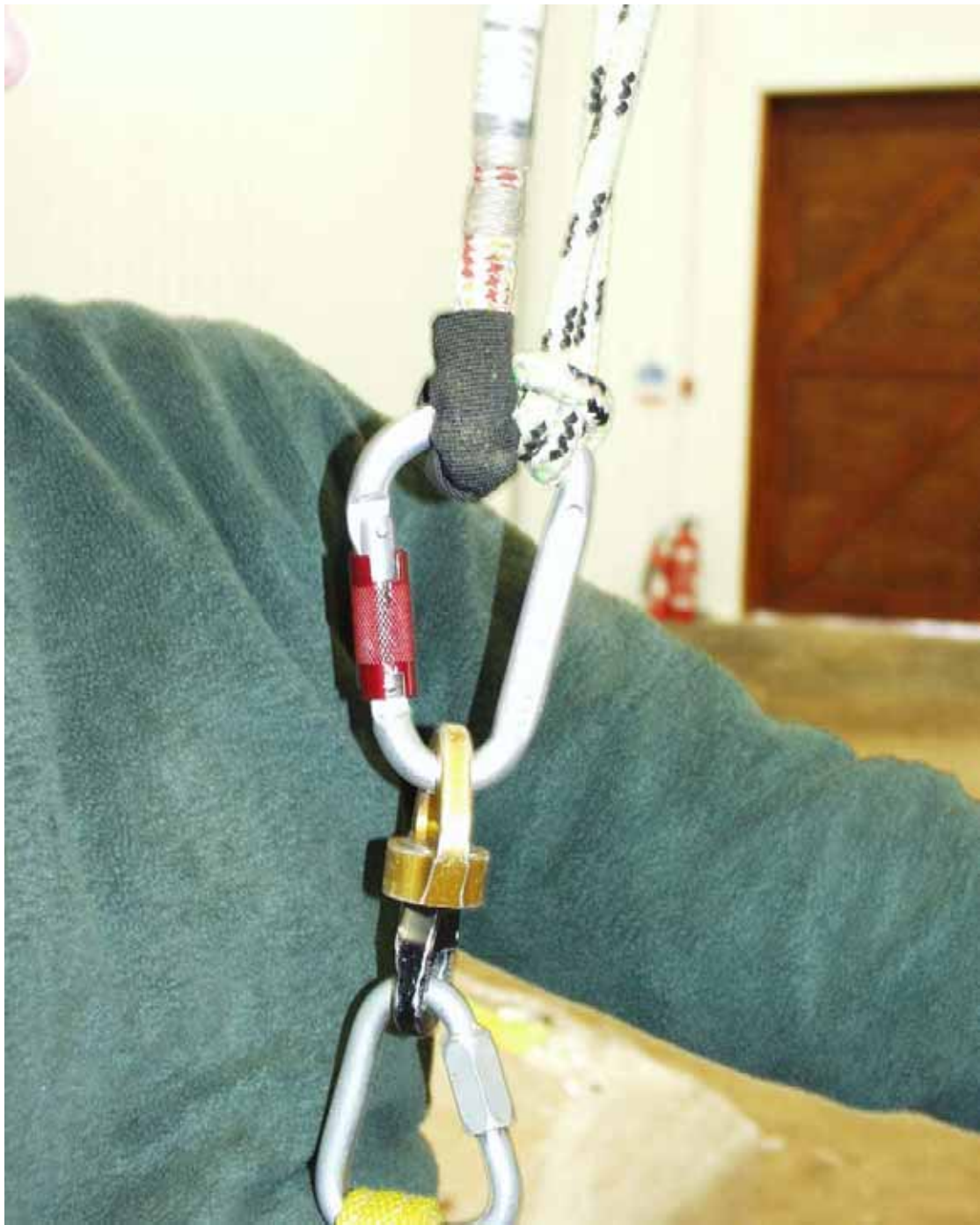

P3120028.jpg

Figure 11 – Lark's foot knot.



P3120014.jpg

Figure 12 – Split support line.



P3120018.jpg

Figure 13 – Use of pulley on support rope.



P3120020.jpg

Figure 14 – Alternative use of pulley.

ANNEX A - KARABINERS ACQUIRED BY HSL FOR EXAMINATION AND TEST

DMM

Parts of karabiner supplied by Fred Hall during visit to factory

Ovalock 2-way supplied during factory visit

Ovalock 3-way supplied subsequent to factory visit

HB Wales - HMS

Petzl

1 X Amd

1 X William

Kong - Supplied by Fujikura.

ISC - Mongoose 4-way supplied by Denny Moorhouse.

Svensk Tradvard - Reverse action karabiner supplied by Honey Bros'.

Faders Klettersteig - supplied by Lyon Equipment.

Faders Twist – supplied by Tavistock chainsaws

Edelrid - supplied by Tavistock chainsaws

ANNEX B - MEMBERS OF PEER REVIEW GROUP

Mr C White – AFAG, Arboricultural Association and ISA.

Mr W Robb (Newton Rigg College) - Forestry Contracting Association.

Mr S Biggs – AFAG, TCIA.

Mr G Watson - SAC Arboriculture Services, Training Standards Verifier N.P.T.C & LANTRA Awards.